

Water



Craft Brewer Course

Kim L. Johansen
Master Brewer
Department of Food Science

UNIVERSITY OF COPENHAGEN

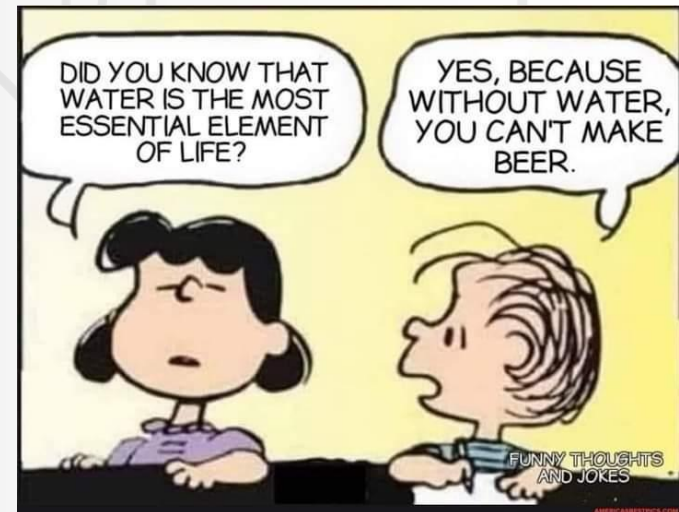

The water cycle

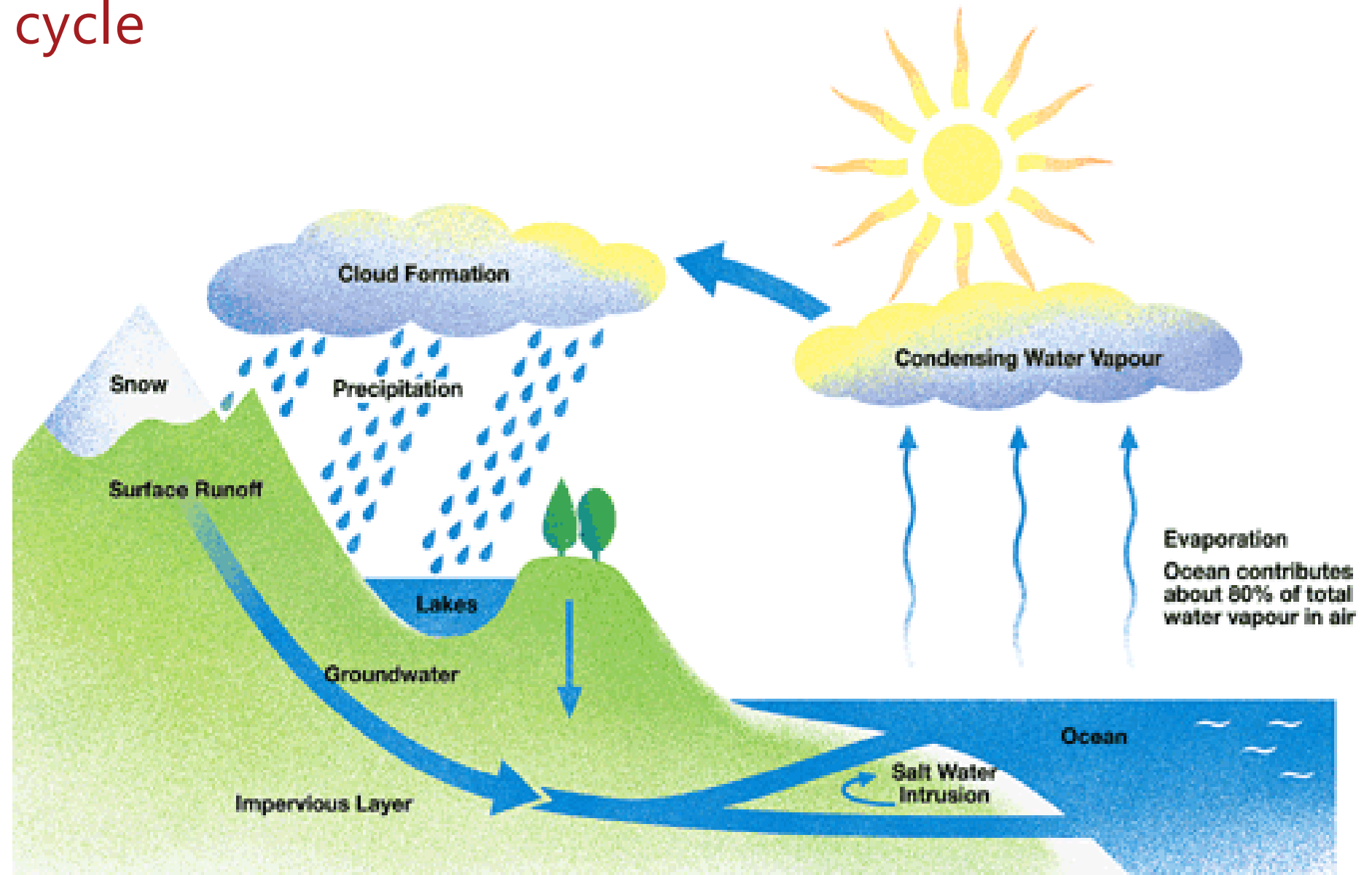

The sources of water supplies

Borehole water

- Usually been in the ground a long time
- Consistent quality
- Free from modern contaminants and micro-organisms
- High in dissolved mineral salts

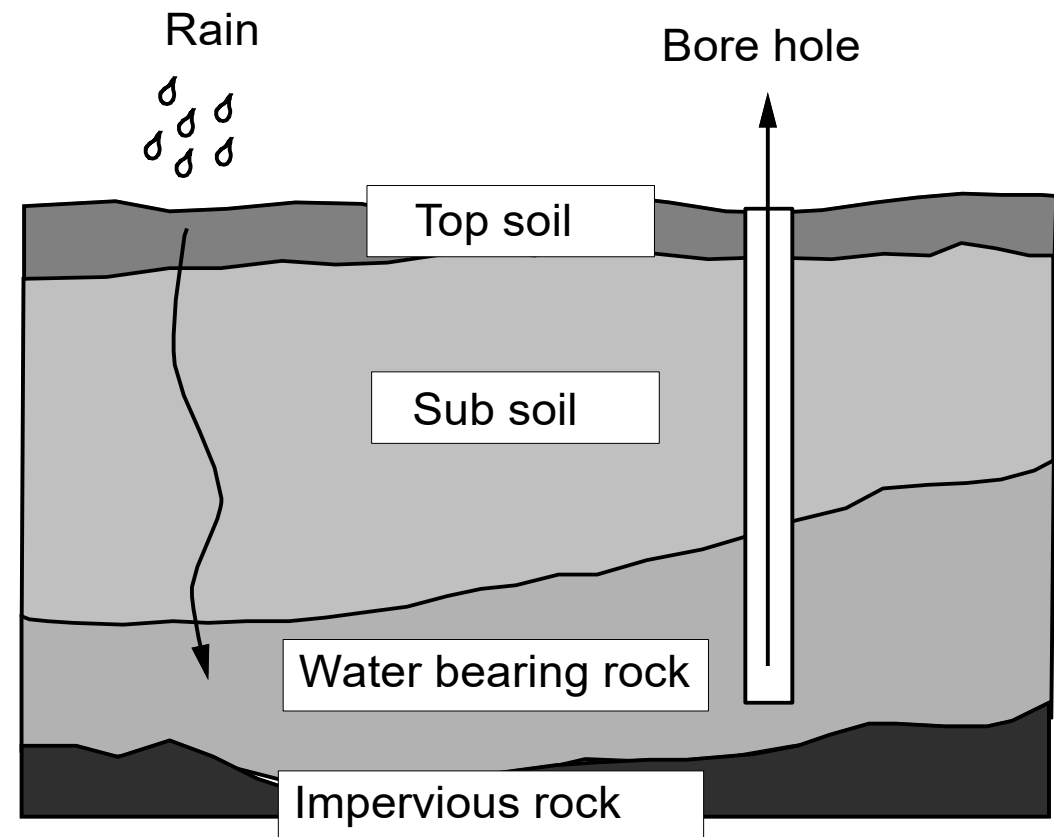

The sources of water supplies

Surface water

- Run off into reservoirs.
- Usually soft water with few dissolved mineral ions.
- Tends to contain microbial & organic contaminants.
- Clogging, sand fines

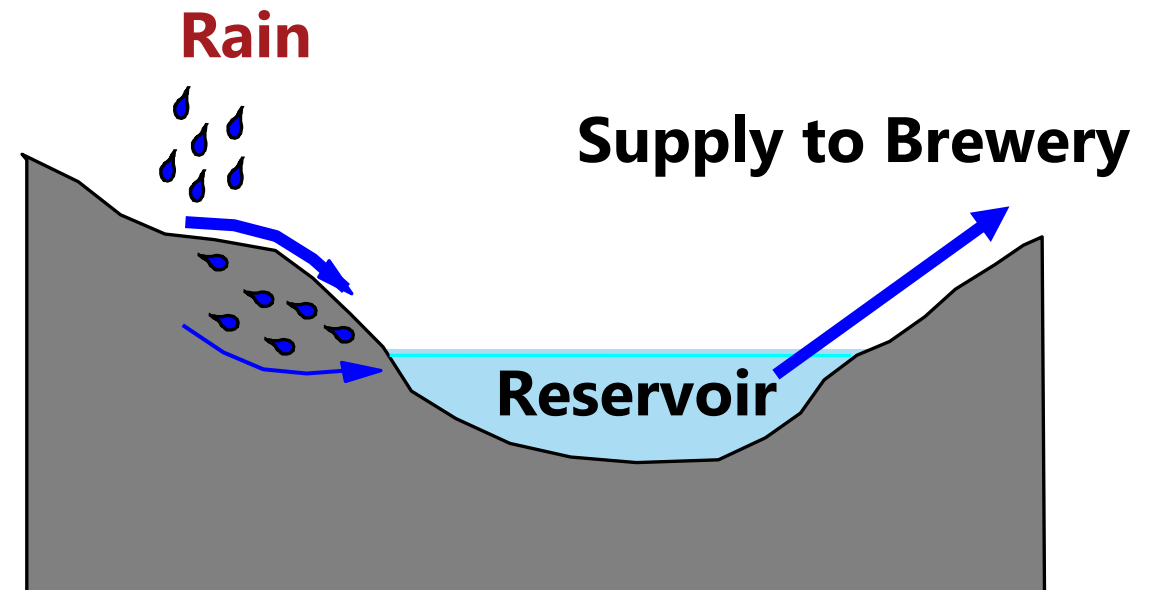

Brewing water

salts, hardness, pH

Historical Brewing Water

- Traditional **lagers** are brewed with **soft water** (low in mineral content)
- Traditional **ales** are brewed with **hard water** (mineral rich water)

TOWN	Type of Beer	TDS	Na	Mg	Ca	NO ₃	Cl	SO ₄	HCO ₃
Burton	Pale Ale	1300	54	24	352	18	16	820	320
Midlands	Mild Ale	750	28	48	148	N/a	77	240	260
Dublin	Stout	340	12	18	132	5.5	15	15	130
Yorkshire	Bitter		23	17	105		30	66	153
London	Ales		24	4	90		18	58	23
Munich	Dark Lager	280	6	30	106	3	2	8	120
Pilsen	Light Lager	50	2	1	10	N/a	5	6	15
Vienna	Amber Lager		8	60	200		12	125	120
Dortmund	Dortmund		69	23	260		106	240	270
California	US Pale Ale +		15	10	12		13	17	74

- TDS - Total dissolved Solids
- Concentrations in mg/l = ppm
- Today the brewing liquor can be 'designed' by water treatment

Water Hardness

Water hardness is a measure of the amount of dissolved minerals. In natural waters the main constituents are **Ca²⁺** and **Mg²⁺** ions.

$$\text{Hardness} \approx [\text{Ca}^{2+}] + [\text{Mg}^{2+}]$$

Water hardness affects cleaning effectiveness, can deposit on fittings, heating elements, and within pipes, and can affect the flavour of water and beer.



Water scale in a pipe

Temporary Hardness

Temporary Hardness is the Ca^{2+} and Mg^{2+} dissolved along with carbonate (CO_3^{2-}) and bicarbonate (HCO_3^-) ions. Temporary refers to the fact that these compounds will re-associate and precipitate from solution when boiled.

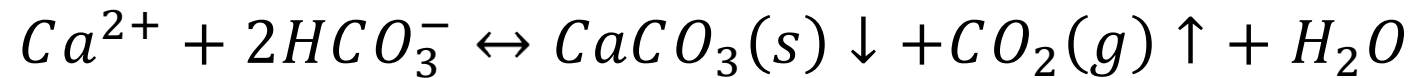

Temporary hardness = **carbonate hardness**.

Permanent Hardness

Permanent Hardness is the Ca^{2+} and Mg^{2+} dissolved along with sulfate (SO_4^{2-}) and chloride (Cl^-). Permanent hardness will not precipitate with boiling and requires treatment such as ion exchange for removal.

Permanent hardness = **non-carbonate hardness**

Total hardness = temporary hardness + permanent hardness

Process Water

Water for malting and brewing should be:

- potable, clear, taste- and odourless

Undesirable parameters are:

- High level of microbiological contamination
- High level of organic material (KMnO_4 number)
- Chlorination
- Iron < 0.5 mg/l
- Manganese < 0.3 mg/l

Water Chemistry – pH

Water dissociation $\text{H}_2\text{O} \rightleftharpoons \text{H}^+ + \text{OH}^-$

1909 - Prof. S.P.L. Sørensen at Carlsberg Laboratories defines pH as the negative decimal logarithm of the hydrogen ion concentration in solution i.e. $-\log [\text{H}^+]$



Prof. S.P.L. Sørensen

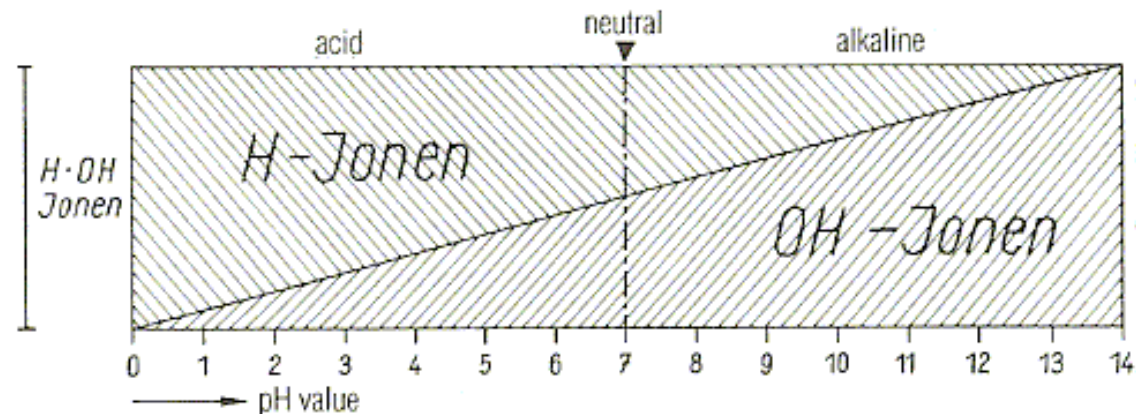

Concentration of H⁺ and OH⁻ ions

Water Chemistry – pH

pH values

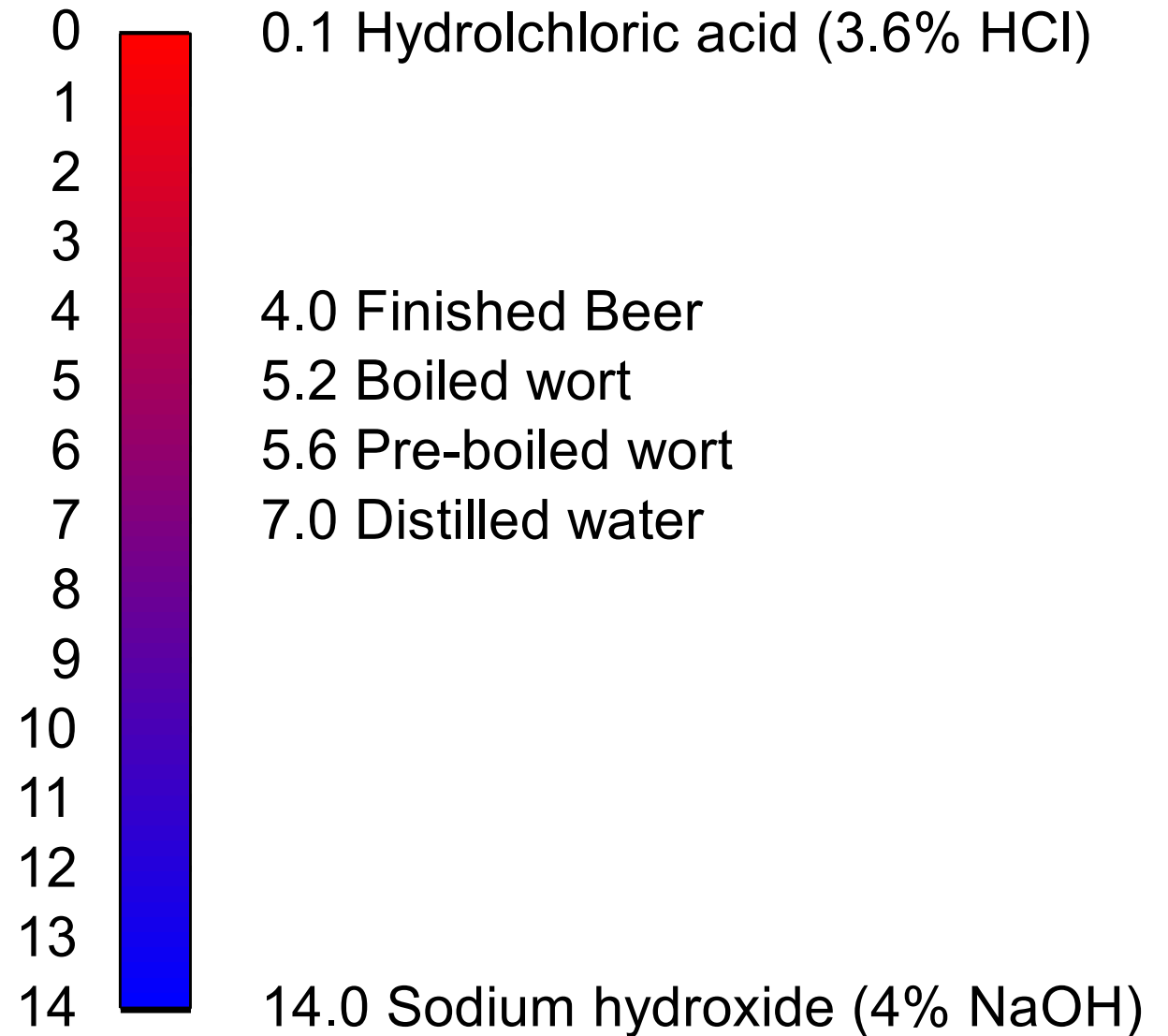

Process Water

- Lager beer ("Pilsner")
 - Soft water with low mineral content, low carbonates
 - Calcium ions are important at levels > 30 mg/l.
- Pale ales and bitters
 - Bicarbonate < 60 mg/l. Calcium > 125 mg/l
 - Sulphate $>$ Chloride to bring out the bitter flavours
- Mild ales and stouts
 - Carbonates < 60 mg/l
 - Calcium > 75 mg/l for mild ales
 - Calcium > 30 mg/l for stouts

Water treatment in the brewery

Softening – Methods for reduction of hardness

- Lime softening
- Ion exchange
- Nano filtration (NF)
- Reverse osmosis (RO)

Lime softening reactor

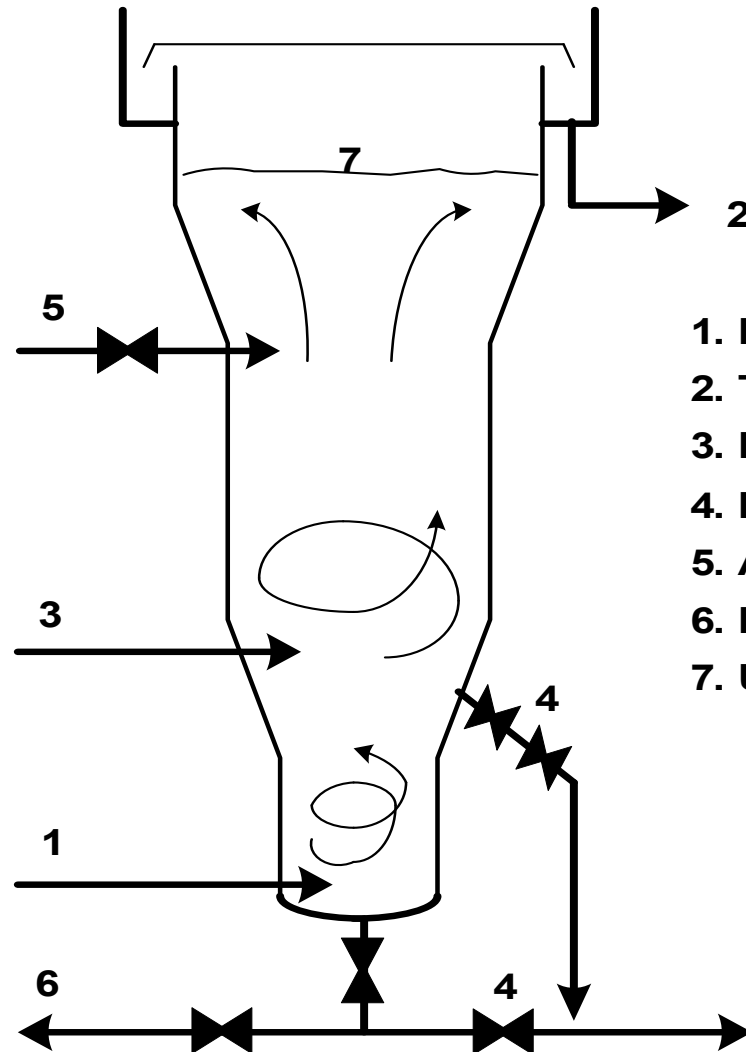

NOTE: Reaction time is <1 min., but in order to form filterable "flocs" the holding time of the reactor is 10-12 min.

Ion Exchange – strong cation

Softening by removal of all hardness

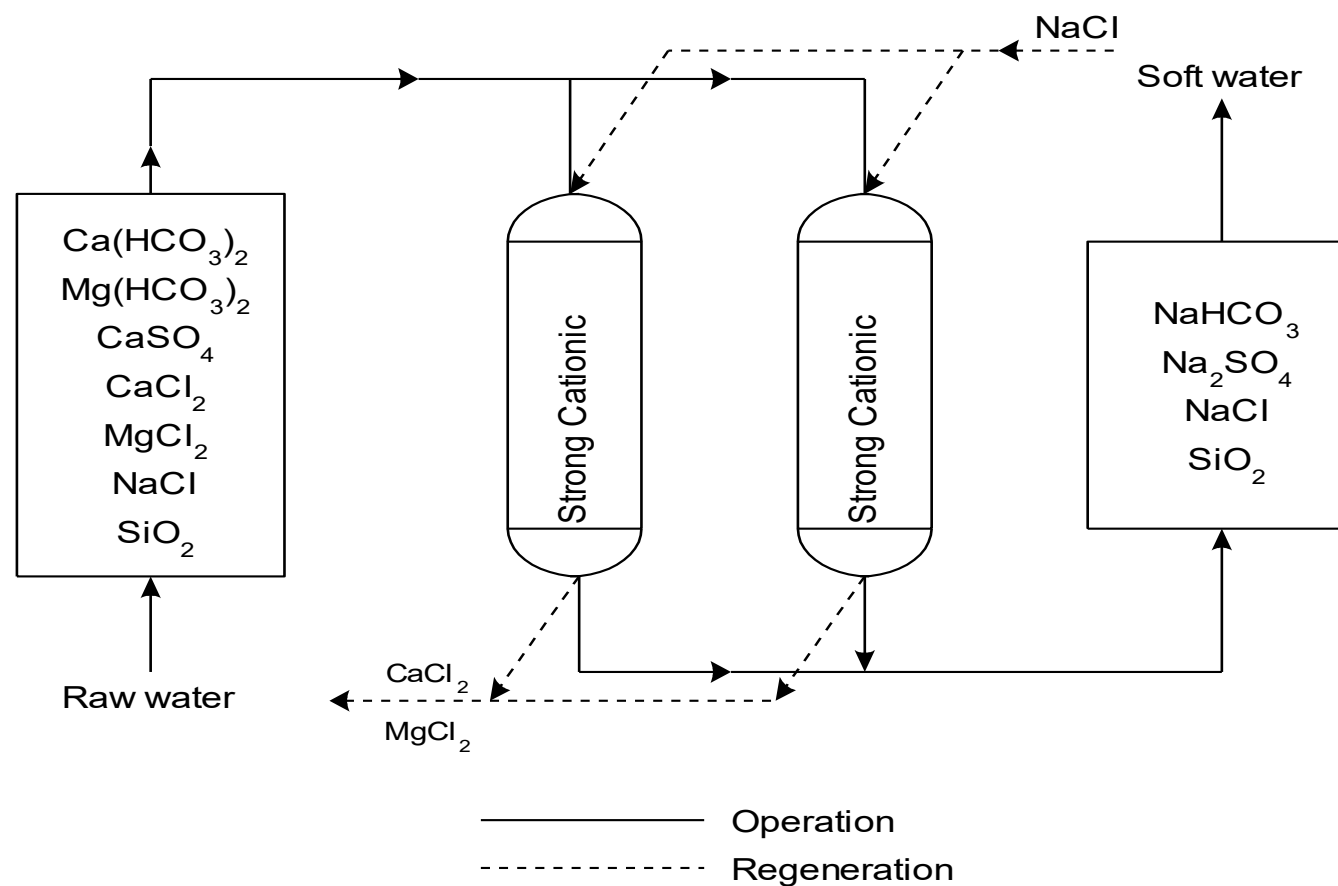

Affinity order: $\text{Mn}^{3+} > \text{Fe}^{3+} > \text{Ca}^{2+} > \text{Mg}^{2+} > \text{Na}^+ > \text{H}^+$
 Result: Ca^{2+} and Mg^{2+} ions get exchanged with Na^+ ions

Ion exchange plant – small brewery in Denmark



Membrane filtration

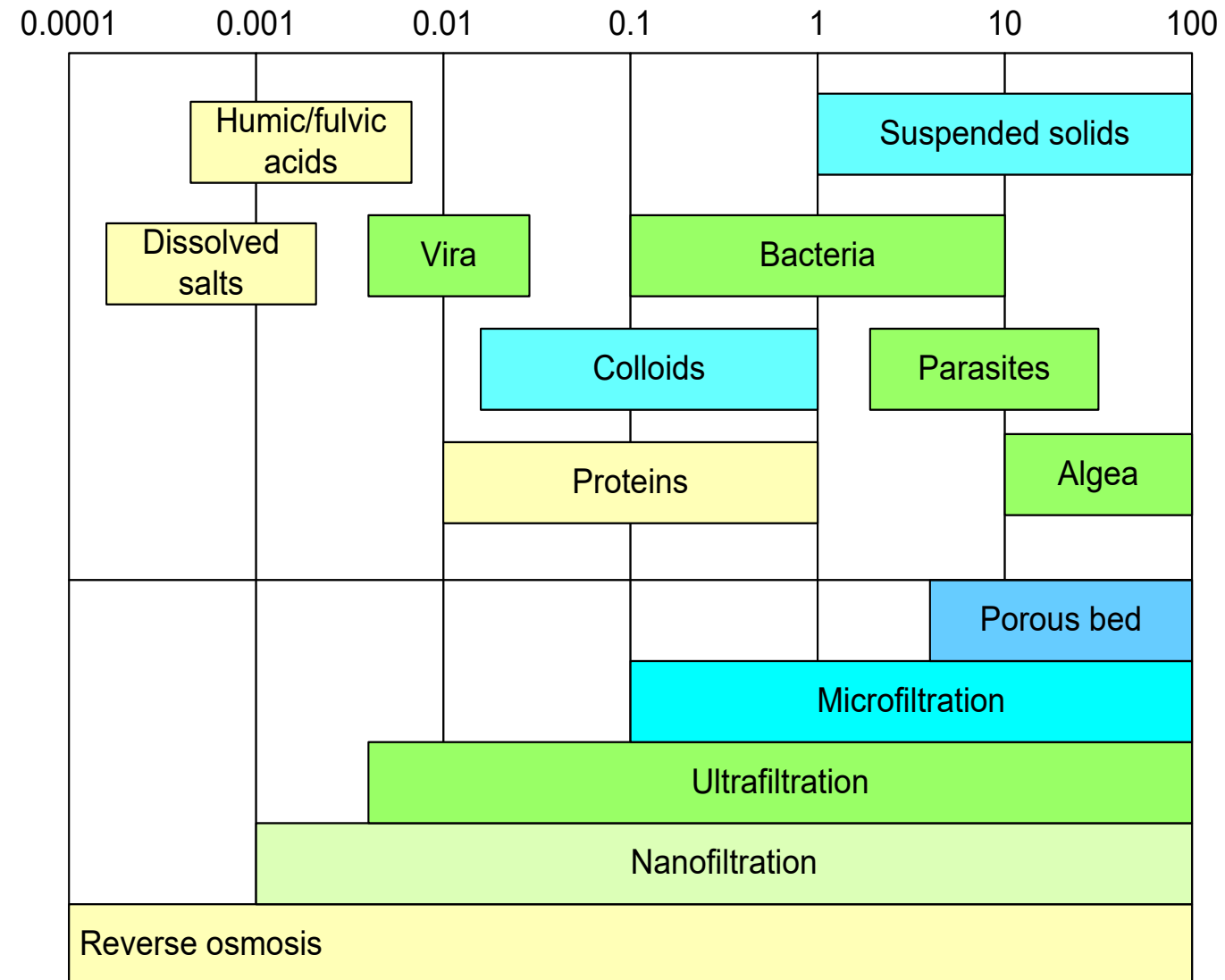

Summary questions

- What are the characteristics of water traditionally used for ales?
- What are the characteristics of water traditionally used for pilsners?
- Which kind of hardness are we operating with? – and what are the differences?
- What is pH?
- How can we soften water?

Back-up slides

Self-study

Water supply to the brewery

Water of different quality needs different treatment

Parameter	Surface	Borehole	Municipal
Temperature	Varies with season	Constant	Varies with season
Turbidity	Varies, can be high	Low	Varies, usually low
Color	Varies w/ soil, season	Low	Varies, usually low
Dissolved O ₂	Saturated	Low	Saturated
Aggressive CO ₂	Low	Usually present	Usually Low
Iron	Varies, usually low	Usually present	Varies, can be high
Hardness	Varies, usually low	Varies w/ rock strata	Varies, can be high
Nitrates	Agriculture = High	Low	Usually Low
Other Minerals	Varies, usually low	Varies	Varies, usually low
Micro-organisms	Will be high	Usually very low	Usually very low

Minerals in Brewing Water

Name	Ion	Impact	Recommended
Calcium	Ca ²⁺	water hardness, stimulate proteolytic and amylolytic enzymes, reduce pH, prevent haze and gushing	40 - 150 mg/l
Magnesium	Mg ²⁺	water hardness, reduce pH, co-factor for enzymes, bitter flavour	< 30 mg/l
Sodium	Na ⁺	full & sweet palate, salty perception > 150 mg/l	< 120 mg/l
Potassium	K ⁺	salty perception > 150 mg/l	< 120 mg/l
Iron	Fe ²⁺ and Fe ³⁺	saccharification, hazy wort, inhibit yeast, harsh bitter flavour, colloidal stability, metallic taint, Fe ²⁺ enhances beer oxidation	< 0.1 mg/l
Zinc	Zn ²⁺	stimulates fermentation, yeast flocculation, oxidation, haze, flavour stability	0.15 - 0.5 mg/l >0.2 mg/l in wort
Copper	Cu ²⁺	yeast nutrition, oxidation, colloidal and flavour instability	< 0.1 mg/l
Manganese	Mn ²⁺	yeast nutrition, enhance enzyme activities during mashing, co-factor for yeast enzymes, colloidal instability	< 0.05 mg/l
Ammonium	NH ₄ ⁺	indicator of a contaminated water source	< 0.5 mg/l

Minerals in Brewing Water

Name	Ion	Impact	Recommended
Bicarbonate & Carbonate	HCO_3^- & CO_3^{2-}	alkalinity, increases pH of wort	< 50 mg/l
Hydrogen Sulphide	H_2S	bacterial growth in water, aroma of drains or rotten eggs	
Sulfate	SO_4^{2-}	bitterness or dryness	10 - 250 mg/l
Chloride	Cl^-	perception of malt or fullness, corrosion	< 40 mg/l
Nitrate and Nitrite	NO_3^- and NO_2^-	indicate polluted water, toxic to yeast	< 25-50 mg/l < 0.1 mg/l
Silicate	SiO_3^{2-}	haze in combination with Calcium	< 20 mg/l
Phosphate	H_2PO_4^- , HPO_4^{2-} , PO_4^{3-}	indicate pollution of water source, phosphate buffer	< 1 mg/l
Fluoride	F^-	hardly problem in brewing	< 1.5 mg/l

Raw water treatment

